

Contents

Symbols used in this manual	7
Symbols on the power tool	7
For your safety	7
Overview	8
Technical specifications	8
Instructions for use	9
Maintenance and care	10
CE-Declaration of Conformity	10
Disposal information	10
Exemption from liability	10

Symbols used in this manual

WARNING!

Denotes impending danger.

Non-observance of this warning may result in death or extremely severe injuries.

CAUTION!

Denotes a possibly dangerous situation.

Non-observance of this warning may result in slight injury or damage to property.

NOTE

Denotes application tips and important information.

Symbols on the power tool



Before switching on the power tool, read the operating manual!



Short-circuit-proof safety transformer



Device is suitable for use indoors only. Do not expose the device to rain. Store electric power tool and batteries in dry rooms.



Disposal information
(See page 10)!

For your safety

WARNING!

Read all safety warnings and all instructions. Failure to follow the warnings and instructions may result in electric shock, fire and/or serious injuries. **Save all warnings and instructions for future reference.**

Before using the battery charger, read and follow:

- these operating instructions,
- the "General safety instructions" on the handling of power tools in the enclosed booklet (leaflet-no.: 315.915),
- the currently valid site rules and the regulations for the prevention of accidents.

This appliance is not intended for use by persons (including children) with reduced physical, sensory or mental capabilities, or lack of experience and knowledge, unless they have been given supervision or instruction concerning use of the appliance by a person responsible for their safety.

Children should be supervised to ensure that they do not play with the appliance.

If the supply cord is damaged, it must be replaced by the manufacturer, its service agent or similarly qualified person in order to avoid a hazard.

Intended use

The battery charger CA 10.8/18.0 is designed for charging FLEX batteries of types

- AP 10.8 (2.5 Ah),
- AP 10.8 (4.0 Ah),
- AP 10.8 (6.0 Ah),
- AP 18.0 (2.5 Ah) and
- AP 18.0 (5.0 Ah).

The battery voltage must match the battery charging voltage of the charger. Otherwise there is danger of fire and explosion.

Safety instructions for the battery charger

- **Keep the battery charger away from rain or moisture.** Penetration of water in the battery charger increases the risk of an electric shock.
- **Keep the battery charger clean.** Contamination can lead to danger of an electric shock.
- **Before each use, check the battery charger, cable and plug.** If damage is detected, do not use the battery charger. **Never open the battery charger yourself.** Damaged battery chargers, cables and plugs increase the risk of an electric shock.
- **In case of damage and improper use of the battery, vapours may be emitted.** Ventilate the area and seek medical help in case of complaints. The vapours can irritate the respiratory system.
- **Do not place any objects on the battery charger and do not place the battery charger on soft surfaces.** There is a risk of fire.
- **Always check that the mains voltage matches the voltage indicated on the rating plate of the battery charger.**

Overview

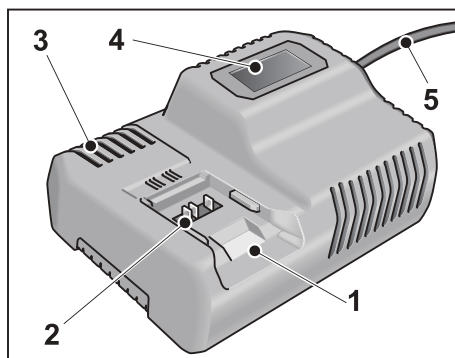

- 1 Slot for battery
- 2 Contacts
- 3 Ventilation slots
- 4 Display for indicating the operating status
- 5 Power cord with plug

Technical specifications

Device	Battery charger CA 10.8/18.0	
Input voltage	V~/Hz	220-240/ 50-60
Charging voltage	V-	12/20
Charging time (depending on charge state)		
	AP 10.8/2.5 min	40
	AP 10.8/4.0 min	40
	AP 10.8/6.0 min	55
	AP 18.0/2.5 min	40
	AP 18.0/5.0 min	45
Operating temperature	°C	0-55
Weight (without battery)	kg	0.89
Protection class		II / □